

Benefits:

- Improved store aesthetics, by having a store entrance free from obstacles
- Shrinkage reduction
- Minimization of false alarms with its beam steering technology
- Combination of loss-prevention and product identification in one system
- Provides data to detect which products suffer more theft attempts
- Very quick detection
- Continuous detection field
- One master unit can be connected to a slave unit, which reduces costs

Applications:

- Loss prevention at retail stores
- Loss prevention at warehouses

Watch a video of RFID loss-prevention on [YouTube](#)

Product overview

AdvanSafe is an **overhead loss prevention system** based on RFID UHF that detects the tagged items that pass through an entrance, verifies if those items have been purchased, and triggers an acoustic and/or visual alarm if any item has not been purchased.

AdvanSafe uses **multiple antenna beams** and **electronic beam steering** to detect which tags are static and which are moving, avoiding false alarms.

AdvanSafe can use **four configurations** for checking if a tagged item has been paid:

- Checks the EAS bit of NXP chips
- Checks if the EPC code includes a pre-defined pattern that signals that the product has or not been paid
- Checks against the POS database if the product has been purchased
- Checks bulk theft: trigger an alarm if a certain number of tags are read in a certain time period (e.g. a few seconds).

AdvanSafe uses **master units** and **slave units**:

- The master unit has an integrated reader, antenna, controller, acoustic alarm and visual alarm.
- The slave unit comprises antenna and visual alarm.

One slave unit can be connected up to one master unit. This reduces costs for stores with wide entrances.

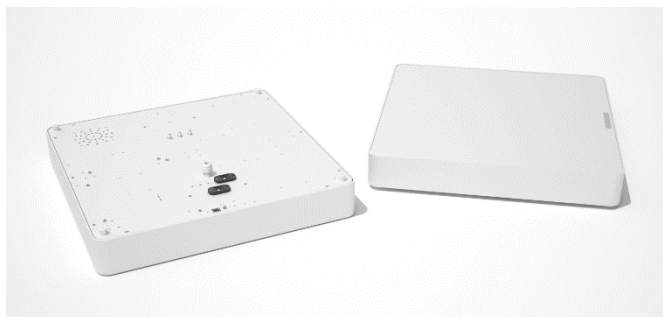

AdvanSafe works with any hard and soft Gen2 RFID UHF tags.

The tag chip and inlay chosen should provide a reading distance longer than the height at which AdvanSafe-200 will be installed in all tag orientations.

AdvanSafe-200 includes advanced processing techniques for minimizing false alarms.

AdvanSafe can be ordered in 2 models:

- Suspended wires mount
- Ceiling mount



AdvanSafe-200™ Overhead RFID loss prevention system with beam steering

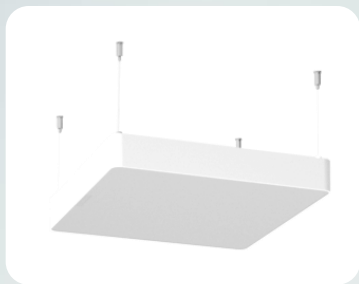

Connection to AdvanCloud

AdvanSafe can be optionally connected to AdvanCloud cloud-based software platform.

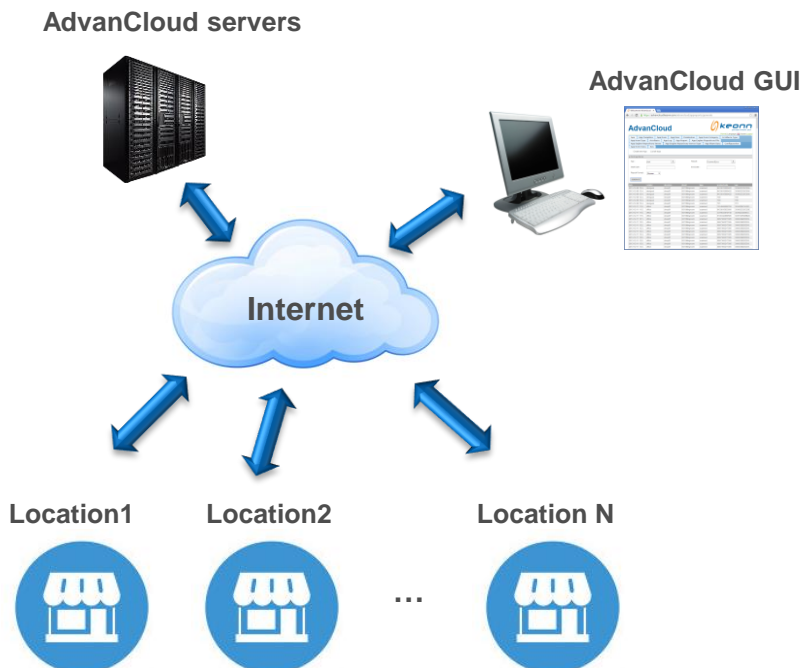

The products that trigger an alarm can be shown on a **smartphone** managed by store staff or security staff, in order to:

- Thwart theft attempts
- Register the event: false alarm, thwarted theft, theft

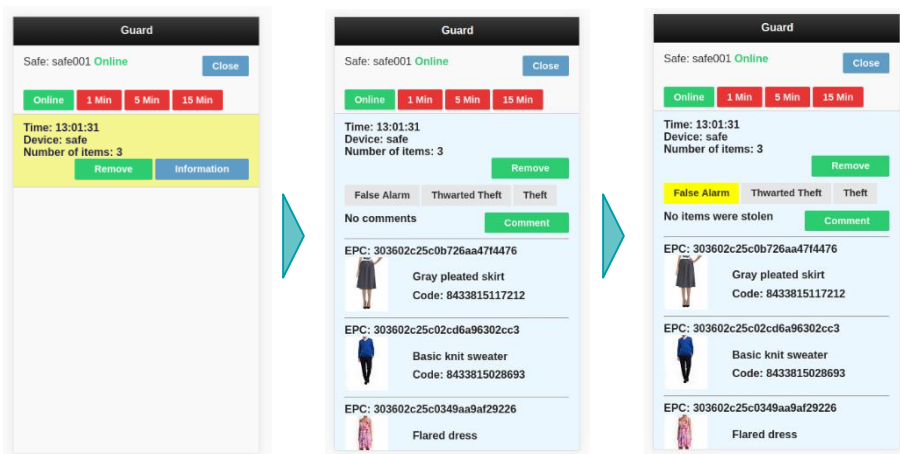

This information can then be analyzed for **business intelligence** purposes:

- Theft attempts by day and time of day
- Products that suffer more theft attempts
- Stores with more theft activity
- ...

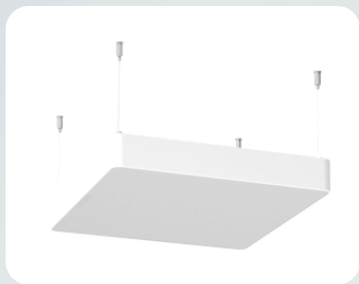

Specifications

Operating Frequency	FCC (NA, SA) (902 - 928) MHz ETSI (EU, IN) (865.6 - 867.6) MHz MIC (KR) (910 - 914) MHz SRRC-MII (P.R.China) (920.125 – 924.875) MHz (1) Australia (AU) (920.750 – 925.250) MHz New Zealand (NZ) (922.250 – 927.250) MHz Israel (IS) (915.0 - 917.0) MHz (2) Japan (JP) (916.8 - 920.8) MHz (3) Brazil (902 – 907.5) MHz (915 – 928) MHz by using channel selection Chile (916 – 928) MHz by using channel selection Peru (916 – 928) MHz by using channel selection Taiwan (922 – 928) MHz by using channel selection Open Region (4) (865 – 869) MHz and (902 – 928) MHz (by using channel selection) (5)
Detection Height	2 - 3 m (recommended) Maximum: 3.5 m (Use maximum height with caution. Read distance depends highly on tag model and products being used)
Radiation pattern	Multiple beam
Beam width	90° / 40° (surrounding widths of all beams)
Polarization	Circular
Alarm Light	Light Emitting Diode (LED)
Alarm Audio	Signal Buzzer
Relay output	Dry contact output 24 VDC / 0.5 A / Resistive load
Alarm function Preset	System gives audio and light alarm by detection of any of the EAS supported modes
Power supply	Power over Ethernet
Energy Consumption	< 14 W max., < 3 W idle
Reader Power	Maximum 31,5 dBm (may be limited to conform to country or area regulations) Recommended max. 30 dBm
Radiated power	2 W ERP, 3.2 W EIRP
Interface	Ethernet and USB
Transponder Protocol Standard	EPC Class1 Gen2
Operating System	Linux - Fully open
Temperature range	-20°C to +55°C
Dimensions	Suspension mount 460 mm x 460 mm x 80 mm (18.1 in x 18.1 in x 3.1 in) Ceiling mount 460 mm x 460 mm x 121.5 mm (18.1 in x 18.1 in x 4.8 in)
Weight	Suspension mount Master unit: 5.655 Kg (12.5 lb) - Slave unit: 5.060 Kg (11.2 lb) Ceiling mount Master unit: 6.375 Kg (14.1 lb) - Slave unit: 5.780 Kg (12.8 lb)
Material Housing	Aluminum and methacrylate
Color	Off white
Human exposure	EN 50364
EMC	EN 301 489, EN 300 220
Air Interface (EU)	EN 302 208 v1.2

(1) PRC band is only available in CH version.

(2) Israeli band is only available in CH version.

(3) Japanese band is only available in CH version. RF conducted power is limited to 30 dBm.

(4) Open channel specified applies to ETSI/FCC versions. CH versions open channel is defined between 840 to 845 MHz and 920 to 925 MHz.

(5) Band is defined as a carrier sub-set from FCC. There is no specific Surface Acoustic Wave (SAW) filter for the band. Given the maximum conducted power there shouldn't be problems with local regulation.

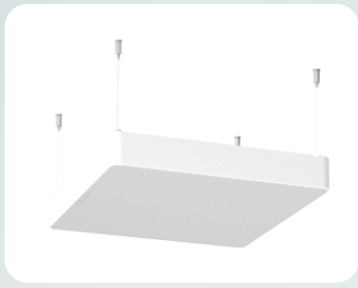

Mechanical specifications of the model with suspended wires

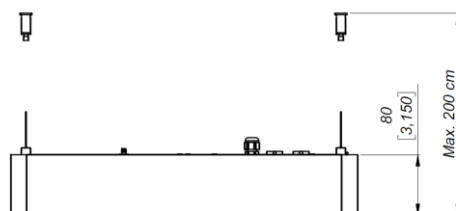
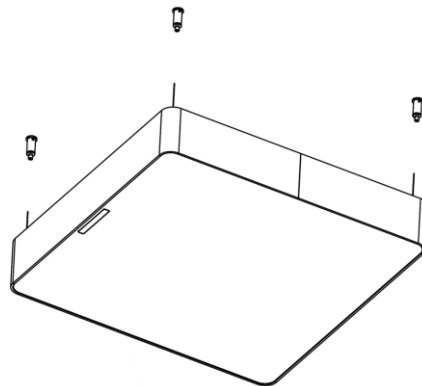
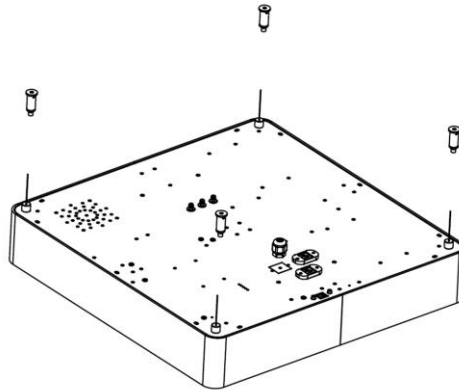
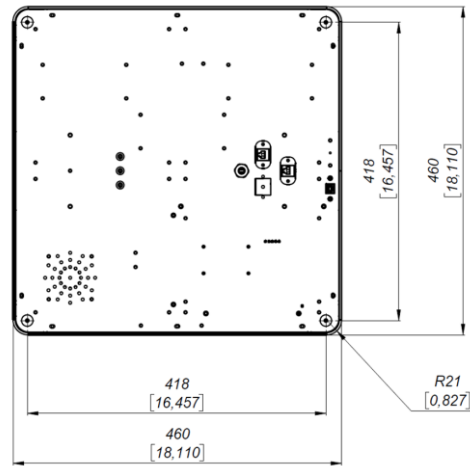

Dimensions in millimeters [inches]

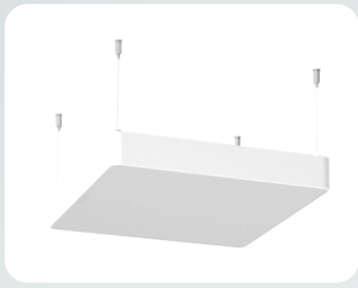

Mechanical specifications of the model ceiling mount

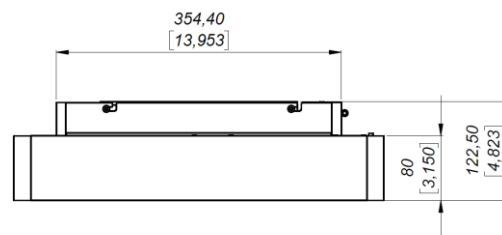
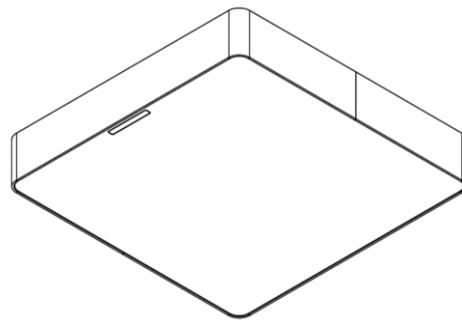
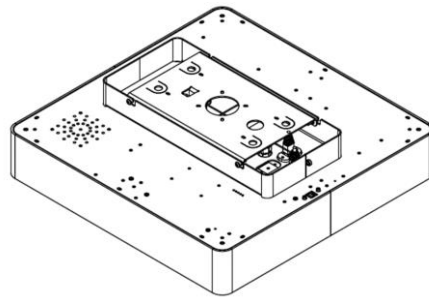
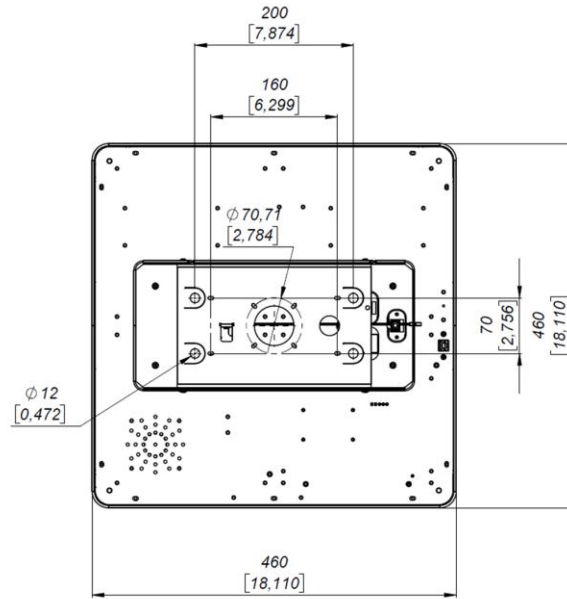

Dimensions in millimeters [inches]

AdvanSafe-200™

Overhead RFID loss prevention system with beam steering

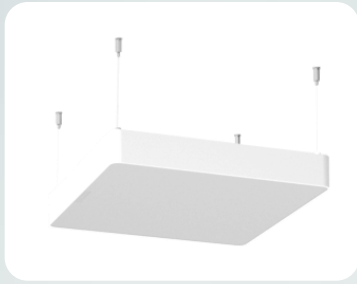

Product codes for ordering

ADSF	-	o	t	m	FF	-	BS	-	mmm	
										o = overhead
		o								overhead
										t = type
				m						master
				s						slave
										m = mount
				c						Ceiling mount (attached to the ceiling or suspended with a pole, pole not included)
				s						Suspended with metallic wires (included)
										FF = frequency band
					EU					ETSI
					US					FCC
					CH					China
										BS = beam shape
							22			Pencil beam shape (maximum gain)
										Model
									200	model number

For example:

- **ADSF-omcEU-22-200:**
 - AdvanSafe
 - Overhead
 - Master unit
 - Ceiling mount (attached to the ceiling or suspended with a pole)
 - ETSI frequency band
 - Pencil beam shape
 - Model 200
- **ADSF-ossUS-22-200:**
 - AdvanSafe
 - Overhead
 - Slave unit
 - Suspension mount
 - FCC frequency band
 - Pencil beam shape
 - Model 200

Keonn Technologies S.L.
Pere IV, 78-84, planta 6, 3a
08005 Barcelona, Spain

Tel: +34 931 814 477
info@keonn.com
www.keonn.com

Copyright © Keonn Technologies S.L.
All rights reserved.
Information in this publication supersedes all
earlier versions. Specifications subject to change
without notice.

Follow us on twitter: @KeonnTech